

## Lightweight, 3 dBd Base Station and Marine Antenna for the 150 MHz Band

### DESCRIPTION

- CXL 2-3LW/... is a 3 dBd, vertically polarised, omnidirectional base station and marine antenna, which covers the VHF-band in 5 models.
- Provided with the sturdy "LW" mast mount – a lightweight, multipurpose, epoxy-coated mounting bracket made of non-corrosive aluminium.
- The accompanying U-bolts and fittings are made of stainless steel.
- To be mounted on vertical or horizontal mast tubes, 16 to 54 mm in outer diameter.
- The cable can be led either on the outside or along the inside of the mast tube.
- Large bandwidth with respect to both VSWR and gain.
- The phasing of the radiating elements is adjusted to yield maximum gain in the horizontal plane, with the level of the sidelobes reduced to a minimum.
- The carefully designed, broad-banded antenna element is sealed in a high-quality conical glass fibre tube with low wind-load, which will ensure performance undisturbed by corrosive environments.
- To substantially reduce noise caused by atmospherical discharges, all metal parts in the antenna are DC-grounded. Consequently, the antenna shows a DC-short across the coaxial cable.
- The CXL 2-3LW/... is a vibration-proof, lightweight, slim-line, corrosion resistant, modern style base station and marine antenna.



### SPECIFICATIONS

Electrical	
Model	CXL 2-3LW/...
Frequency	Bands within 139 - 175 MHz
Antenna Type	Broad-banded collinear antenna
Max. Input Power	150 W
Polarisation	Vertical
3 dB Beamwidth, E-Plane	30 °
3 dB Beamwidth, H-Plane	Omnidirectional
Impedance	50 Ω
Gain	3 dBd (5.2 dBi)
VSWR	< 1.5:1
Bandwidth	9 MHz
Antistatic Protection	All metal parts DC-grounded (Connector shows a DC-short)
HCM Code(s)	HCM000ND00, 015DE50

Mechanical	
Connection(s)	N(f)
Materials	Shroud : Polyurethane-coated glass fibre Mounting bracket : Seawater resistant aluminium, epoxy-coated Clamps : Stainless steel
Colour	White (RAL 9003)
Wind Area	0.0651 sq. m / 0.70 sq. ft
Wind Load	82 N (160 km/h)
Dia. At Top End	15 mm / 0.59 in.
Dia. At Bottom End	23 mm / 0.91 in.
Height	Approx. 2.8 m / 110.24 in.
Weight	Approx. 1.4 kg / 3.09 lb.
Mounting	On 16 to 54 mm dia. mast tube

Environmental	
Operating temperature range	-30 °C to +70 °C
Survival Wind Speed	290 km/h
Ingress Protection	IP66

### ORDERING

Model	Product No.	Frequency
CXL 2-3LW/s	100000473	139 - 147 MHz
CXL 2-3LW/l	100000092	146 - 155 MHz
CXL 2-3LW/lm	100000091	153 - 162 MHz
CXL 2-3LW/hm	100000093	158 - 167 MHz
CXL 2-3LW/h	100000090	166 - 175 MHz

### TYPICAL VSWR CURVE

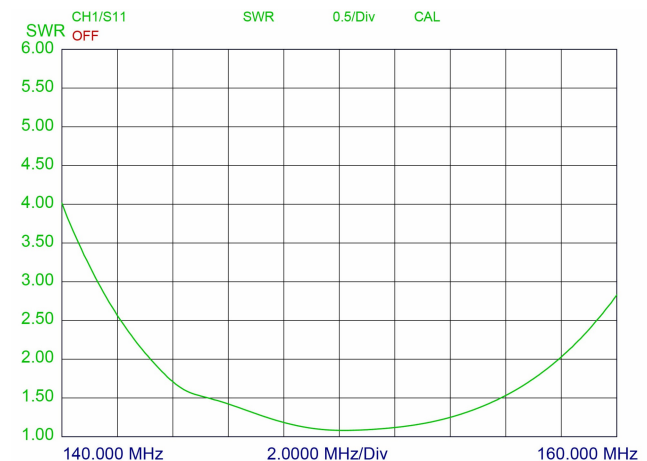

TYPICAL RADIATION PATTERN (E-PLANE)

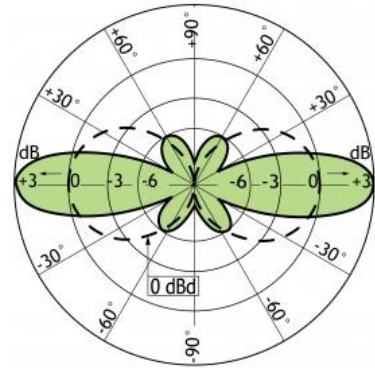

TYPICAL RADIATION PATTERN (H-PLANE)



MULTI-PURPOSE MOUNTING BRACKET

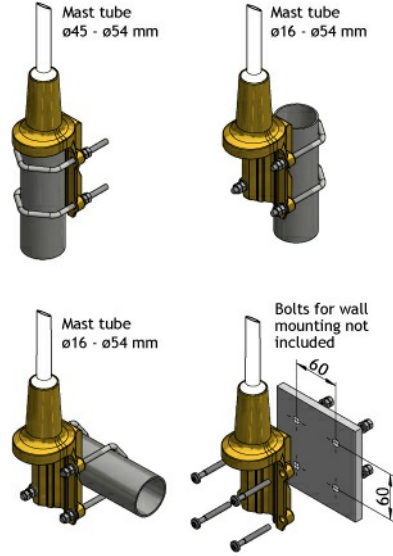

PLEASE NOTE

The antenna is delivered with a DC-connection between the antenna element and the mounting bracket.